



TAMIL NADU TEXTBOOK AND EDUCATIONAL SERVICES CORPORATION

TENDER DOCUMENT

FOR

**SUPPLY AND DELIVERY OF WOODEN COLOUR PENCIL
(BI-COLOUR) TO SCHOOL CHILDREN IN TAMIL NADU ON
ANNUAL RATE CONTRACT BASIS FOR THE YEAR 2022 – 2023**

1.	ADVERTISED ON	:	20.12.2021
2.	PRE-BID MEETING	:	04.01.2022 at 11.00 a.m.
3.	LAST DATE & TIME FOR SUBMISSION OF TENDER	:	20.01.2022 upto 11.00 a.m
4.	DATE & TIME OF OPENING OF TECHNICAL BIDS	:	20.01.2022 at 11.30 a.m

TAMIL NADU TEXTBOOK AND EDUCATIONAL SERVICES CORPORATION

EVK SAMPATH MAALIGAI, D.P.I. Campus

68, College Road,
Chennai – 600 006.

Tamil Nadu, India

Phone: 044-28275851, 044-28278244

Fax : 044-28224493

**Email: adpur.tntbesc@tn.gov.in / jdtntbesc@outlook.com
Website: www.textbookcorp.tn.gov.in / www.tenders.tn.gov.in**

**TENDER DOCUMENT FOR SUPPLY AND DELIVERY OF
WOODEN COLOUR PENCIL (BI-COLOUR) TO THE SCHOOL
CHILDREN IN TAMILNADU ON ANNUAL RATE CONTRACT BASIS FOR THE
YEAR 2022 – 2023**

INDEX		
Chapter. No.	Chapter	Page No.
1.	Scope of the Tender	3
2	Notice Inviting Tender	4-5
3.	Instructions for submission of Technical Bids & Price Bid	6-9
4.	Instructions to the Bidders	10-26
5.	Terms and Conditions of the Tender	27-36
6.	Letter of the Tenderer	37-39
7.	Specifications (Annexure I)	40
8.	Drawings (Annexure II (a), (b) & III)	41-45
9.	Statements, Declarations and Formats (Annexure IV-XII)	46-54
10.	Bank Guarantee for Security Deposit (Annexure XIII)	55-56
11.	Agreement Form (Annexure XIV)	57-59
12.	Price Bid	60

TAMIL NADU TEXTBOOK AND EDUCATIONAL SERVICES CORPORATION

1. SCOPE OF THE TENDER

Supply and Delivery of Wooden Colour Pencil (Bi-Colour) at Block Level

1.1. In order to implement the announcements of the Hon'ble Chief Minister pertaining to the **SCHEME OF SUPPLY OF COST FREE WOODEN COLOUR PENCIL (BI-COLOUR)** (one box of 6 pieces) to the School Children studying in Government & Aided schools in Tamil Nadu for the year 2022 – 2023, the Tamil Nadu Textbook and Educational Services Corporation, hereinafter called as the Corporation, has been entrusted with the task of procuring quality **Wooden Colour Pencil (Bi-Colour)** and distributing the same in time to the school children in accordance with the procedures laid down in the Tamil Nadu Transparency in Tenders Act, 1998 and the Tamil Nadu Transparency in Tenders Rules, 2000.

1.2. The Corporation has proposed to procure **16.08 lakh** boxes of **Wooden Colour Pencil (Bi-Colour)** as per the specifications laid down in the Tender Document to the 120 DEOs and 413 BEOs.

1.3. The successful Tenderers as part of the rate contract shall supply the entire quantity of **Wooden Colour Pencil (Bi-Colour)** as per the Tender Document and deliver them at the designated locations and make replacement of the defective quantity supplied in the manner specified in the Tender.

1.4. The Tamil Nadu Transparency in Tenders Act, 1998 and the Tamil Nadu Transparency in Tenders Rules, 2000 shall apply to this Tender.

1.5. The successful Tenderer shall work closely with the Government of Tamil Nadu and the Corporation in achieving the scheduled targets in terms of quality and quantity.

TAMIL NADU TEXTBOOK AND EDUCATIONAL SERVICES CORPORATION,
CHENNAI-600 006.

Phone: 044-28275851, 044-28278244
 Fax No: 044-28224493
 E.mail: adpur.tntbesc@tn.gov.in /
 jdtntbesc@outlook.com

“EVK Sampath Maaligai”
 No.68, College Road,
 Chennai-600 006.

2.NOTICE INVITING TENDER

Rc.No.10445/PUR-II/2021

Sealed tenders are invited from the manufacturers / suppliers of **Wooden Colour Pencil (Bi-Colour)**. National Bidding will be conducted under two cover system conforming to Tamil Nadu Transparency in Tenders Act,1998 and Tamil Nadu Transparency in Tenders Rules, 2000.

1.	Name of the work	:	Supply and Delivery of 16.08 lakh boxes of Wooden Colour Pencil (Bi-Colour) for the School Children in Tamil Nadu on annual rate contract basis for the year 2022 – 2023.
2.	Cost of Tender Document	:	Rs.5,600/- Payable in the form of Demand Drafts /Banker’s Cheque drawn from a Nationalised /Scheduled Bank in favour of “ Tamil Nadu Textbook and Educational Services Corporation ” payable at Chennai.
3.	Purchase of Tender Documents from the	:	i) Assistant Director (Purchase) , Tamil Nadu Textbook and Educational Services Corporation, EVK Sampath Maaligai, 68, College Road, Chennai-600 006. ii). The same may also be downloaded at free of cost from the following websites: a) http://www.textbookcorp.tn.gov.in b) http://www.tenders.tn.gov.in
4	Sale period of Tender Document	:	On all working days from 20.12.2021 to 19.01.2022 between 10.00a.m. and 5.00 p.m.
5.	Earnest Money Deposit (EMD)	:	Rs. 1,20,000 /- (Rupees One lakh and twenty thousand only)
6.	Date of Pre-Bid Meeting	:	04.01.2022 at 11.00 a.m.
7.	Last Date and Time for Submission of Tender	:	20.01.2022 upto 11.00 a.m.
8.	Due date and time for opening of Technical Bids	:	20.01.2022 at 11.30 a.m. If the due date happens to be a holiday, the bids will be received and opened on the next working day.
9.	Contract Period	:	One year from the date of agreement.

Consortium bids are not acceptable. For all other conditions / instructions please refer bid document.

The Corporation shall not be responsible for any postal delay or any loss of Tenders in transit. The Managing Director, Tamil Nadu Textbook and Educational Services Corporation reserves the right to amend or withdraw any of the Terms and Conditions in the Tender Document or to cancel / reject any one or all the tenders received without giving any notice or assigning any reason therefor.

The Tenderers are requested to view the Website <http://www.textbookcorp.tn.gov.in> & <http://www.tenders.tn.gov.in> for any changes / amendments / corrigendum to the Tender which may be issued before 48 hours of the last date for submission of the Tender.

Managing Director and
Tender Inviting Authority,
Tamil Nadu Textbook and Educational
Services Corporation.
Chennai-6.

**3. INSTRUCTIONS FOR SUBMISSION OF TECHNICAL BIDS
& PRICE BID**

- 3.1** All pages of the Technical Bid should be signed by authorized signatory whose name should be communicated in the prescribed format to the Corporation with office seal without any omission. Facsimile will not be accepted.
- 3.2** The notarized copies of performance certificate and Bankers certificates enclosed for the bids shall be identified as the documents submitted by the bidder over the signature with office seal.
- 3.3** Any document / credential submitted without signature of authorized persons will not be considered for evaluation.
- 3.4** Bidder should produce the originals for the performance / client certificate for verification whenever required with the copies of those certificates enclosed along with the bid.
- 3.5** The downloaded documents shall be properly page numbered and spiral bound and submitted along with necessary documents.
- 3.6** Additional documents, if any called for, for verification in support of the technical bid shall be produced by the Tenderer to the Corporation.

I. PART – A COVER – (TECHNICAL BID)

S.No.	Description	Enclosed Yes/No	Page No.
1	Whether the Tender is submitted in two covers as Part-A Cover (Technical Bid) and Part-B Cover (Price Bid)?		
2	Whether Letter of Authorization / Power of Attorney for signing the Tender Document is enclosed on a Non-Judicial Stamp Paper of value of not less than Rs.100/-?		
3	i) Whether Earnest Money Deposit (EMD) of Rs.1,20,000/- (Rupees One lakh and twenty thousand only) in the form of Demand Draft/Banker's Cheque on any Nationalised Bank/Scheduled Bank in favour of the "Tamil Nadu Textbook and Educational Services Corporation, Chennai," payable at Chennai is enclosed? ii) If EMD exemption is claimed, necessary document for claiming exemption of EMD is enclosed? (ie. NSIC / MSME / DIC certificate)		
4	Whether Profile of the Tenderer as per Annexure IV is enclosed?		
5	Whether self attested Photo copies of the recent Income Tax Returns for the last three financial years 2017-18 to 2019-20, are enclosed?		
6	Whether duly attested Photo copy of the Certificate of GST Registration is enclosed?		
7	Whether Audited Balance Sheets along with Profit and Loss Account and Annual Turnover Certificate (Annexure – V) for the last 3 financial years from 2017-18 to 2019-20 duly certified by Chartered Accountant are enclosed?		
8	Whether the statement of supply orders executed during the last 3 financial years from 2018-19 to 2020-21 in Annexure VI is enclosed along with copies of invoices ?		

S.No.	Description	Enclosed Yes/No	Page No.
9	Whether documentary evidence in support of the production capacity of the Tenderer/ manufacturer is enclosed?		
10	Whether Declaration in Annexure – VII for not having been blacklisted either by Corporation or by Central / any State Government and its Public Sector Undertakings / Government Corporations is enclosed?		
11	Whether Declaration in Annexure – VIII duly signed by the Tenderer is enclosed?		
12	Whether Terms and Conditions of the Tender in original are duly signed in each page of the Tender Document?		
13	Whether a Video CD covering the entire manufacturing process of the manufacturing unit from the raw material stage to the finished product is furnished?		
14	Whether documentary proof for manufacturing of the Wooden Colour Pencil (Bi-Colour) atleast for the last three years has been enclosed? i. Certificate issued by ROC with copy of MOA / NSIC / MSME ii. Copy of invoice pertaining to the years 2018-19, 2019-20 and 2020-21 shall be enclosed		
15	Whether a list of Lab Equipments available in the Tenderer's manufacturing Units is furnished?		
16	Whether a list of Plant and Machinery available in the Tenderer's manufacturing units is furnished?		
17	Whether legal contractual agreement with manufacturer is enclosed? (For Supplier only)		
18	Whether a Self Certificate on sample submission as in Annexure – IX is enclosed?		

S.No.	Description	Enclosed Yes/No	Page No.
19	Whether a Declaration in Annexure - X offering to supply Wooden Colour Pencil (Bi-Colour) boxes not less than the minimum quantity prescribed in the Tender is enclosed?		
20	Whether a Certificate in Annexure XI that Tender forms downloaded from the website have not been tampered is enclosed by the bidder?		
21	Whether Banker's certificate for minimum cash credit facility as per Annexure XII is enclosed?		
22	Whether Three samples of Wooden Colour Pencil (Bi-Colour) boxes as per Specification are furnished.		
23	Whether a summary of list of invoices during last 3 years to show minimum supply history has been enclosed?		
24	In case of supplier the document of the (S.No.9,13,14,15 and 16) of contract manufacturer shall be enclosed.		

II. PART - B COVER (PRICE-BID)

SL.NO	DESCRIPTION	Yes / No
1.	Whether Price-Bid in Part B duly filled-in and signed is enclosed?	

4. INSTRUCTIONS TO THE BIDDERS

4.1. General Instructions:

The Bidders are requested to go through the instructions, terms, conditions and specifications given in the Tender Document carefully. Omissions or Failure to furnish any or all the required information in the Tender Document shall result in rejection of their bid.

4.2.

S.No	Term/Abbreviation	Definition / Expansion
1	Tenderer/Bidder	Tenderer / Bidder means the party who makes a formal offer in pursuance of this tender.
2	Successful Tenderer	Successful Tenderer means the Tenderer as part of the rate contract through the tender process and whose offer is accepted by the Tender Accepting Authority (at the price arrived at by the Corporation after negotiation with L1).
3	Manufacturer	Manufacturer means the firm which manufactures Wooden Colour Pencil (Bi-Colour) .
4	Supplier	The supplier should have a valid legal contractual agreement with Manufacturer with validity for atleast three years beyond the tender opening date, and produce a valid proof of the production capacity from manufacturer.
5	Day	A day means a calendar day.
6	Total Cost in the Price Bid	Total Cost means the total expenditure to be incurred by the Corporation to procure one Wooden Colour Pencils boxes (Bi-Colour) .
7	Purchaser	Purchaser means the Tamil Nadu Textbook and Educational Services Corporation on behalf of Government of Tamil Nadu.
8	Delivery Point	Delivery point means designated location at Block Head Quarters (No.of Blocks:413) (No.of Education Districts: 120) in the State of Tamil Nadu.
9	TNTB & ESC	Tamil Nadu Textbook and Educational Services Corporation.
10	Wooden Colour Pencil (Bi-Colour)	Double edge colour Pencils made up of wood with lead bonded with was used for colouring and drawing.
11	Box of Wooden Colour Pencil	A carton box containing 6 Wooden Colour Pencils (Bicolour) in two rows.
12	EMD	Earnest Money Deposit
13	SD	Security Deposit
14	GST	Goods and Services Tax
15	MSME	Micro, Small & Medium Enterprises
16	NSIC	National Small Industries Corporation

S.No	Term/Abbreviation	Definition / Expansion
17	DIC	District Industries Centre
18	RoC	Registrar of Companies
19	MoA	Memorandum of Association

4.3. Bid Document:

The Bid Document consists of the following

- i. Scope of the Tender
- ii. Notice Inviting Tender
- iii. Instructions for submission of bids & Check list
- iv. Instructions to the Bidders
- v. Terms & Conditions of the Tender
- vi. Letter of the Tenderer
- vii. Specifications **(Annexure I)**
- viii. Drawings **(Annexure II (a), (b) & III)**
- ix. Statements and Declarations **(Annexure IV to XII)**
- x. Price Bid.

4.4. Qualification Criteria:

Such firm submitting more than one bid, either individually or as a partner of a joint venture company except for permitted alternative bids will be ineligible and all the bids in which the bidder is involved will be disqualified. However this does not limit the inclusion of a firm as a sub-contractor in more than one bid.

4.4.1. Minimum Eligibility Requirements:

A) Manufacturer:

The Tenderer shall be a **Manufacturer of Wooden Colour Pencil (Bi-Colour)** atleast for a period of the last 3 financial years. The Manufacturer shall possess valid registration for the manufacture of **Wooden Colour Pencil (Bi-Colour)** issued by the competent Authority. Manufacturer should submit valid documents as per rules in force. The manufacturer should have his own manufacturing unit. The manufacturer shall produce a valid proof for production capacity. **(Copy of valid Certificate of Registration, Chartered engineer certified production capacity and list of critical machinery available should be enclosed)**

B) Supplier:

The supplier should have a valid legal contractual agreement with Manufacturer with validity for atleast three years beyond the tender opening date and produce a valid proof of the production capacity from manufacturer.

(Legal Agreement under the relevant laws should be enclosed)

4.4.2. Turnover:

The average annual turnover of the bidder during the last three financial years from 2017-18 to 2019-20 shall not be less than **Rs.50.00 laksh. (Attach certificate from Chartered Accountant along with audited balance sheet and Profit & Loss Account statement for the last three financial years).**

4.4.3. Production Capacity:

The Tenderer shall have the production capacity with the required minimum Plant, Machinery, Manpower and Laboratory Equipments at the manufacturing units to manufacture at least **5,000** boxes of **Wooden Colour Pencil (Bi-Colour)** per day. The Tenderer shall also have the inbuilt facility for testing the quality of the **Wooden Colour Pencil (Bi-Colour)** to be supplied. (Documentary proof of list of Plant and machineries and Lab Equipments with full address of factory and address proof for factory address should be notarized and enclosed).

4.4.4. Minimum Quantity to be offered:

The Tenderer should offer to supply not less than **1.50 lakh** boxes of **Wooden Colour Pencil (Bi-Colour)** within the contract period of **60 days**.

4.4.5. Past Experience:

The Tenderer should have supplied at least **80,500** boxes i.e. 5% of the tendered quantity of **16.08 lakh** of **Wooden Colour Pencil (Bi-Colour)** in any one of the last 3 financial years. **(Supporting documents including invoices shall be enclosed along with the Tender as per Annexure-VI).**

4.4.6. Cash Credit Facility:

The Tenderer shall have a minimum **cash credit facility of Rs.28.00 lakh** exclusively for this work duly certified by the Banker. **(The original certificate in the prescribed format issued by the Nationalised/Scheduled Bank should be enclosed).**

4.4.7. Samples adhering to Specifications:

The Tenderer shall furnish the required samples conforming to the Specifications prescribed in the tender document.

4.5. Change in Quantity:

Quantity given in the Notice Inviting Tender is approximate and is likely to

vary. The Corporation, if necessary, shall either reduce or increase the quantity mentioned in the tender to the extent of 25% during the contract period of one year.

4.6. Pre-Bid Meeting:

There will be a **Pre Bid meeting on 04.01.2022 at 11.00 a.m. in the Tamil Nadu Textbook and Educational Services Corporation, DPI Campus, Chennai 600 006** during which the prospective Tenderers may seek clarifications about the Tender. The Tenderers shall send their queries in writing if any so as to reach the Corporation at least two days prior to the date of Pre-Bid Meeting. The Tenderers shall view the websites given in the Notice Inviting Tender for updated information like change in date / venue etc., of the Pre-Bid meeting. Failure to attend the Pre-Bid meeting is not a disqualification as it is optional. Only the required clarifications asked in writing shall be valid and taken for consideration. In response to the relevant queries of the prospective Tenderer, clarification will be uploaded on the websites of the Corporation.

4.7 Clarification regarding the Tender Conditions :

A prospective Bidder requiring any clarification with respect to any Tender condition may address the Tender Inviting Authority by letter / Email and the clarifications to the relevant queries will be uploaded on the website of the Corporation before 48 hours of last date and time of submission of tender.

4.8 Amendments to the Tender :

4.8.1. The Corporation reserves the right to amend the tender condition on the basis of clarifications sought for by the prospective Bidders, solely at its discretion up to 48 hrs before (i.e.) two days prior to the last date of submission of Tender. Such amendments shall be uploaded on the Websites:<http://www.tenders.tn.gov.in> & <http://www.textbookcorp.tn.gov.in>

4.8.2. At its discretion the Corporation may or may not extend the due date and time for the submission of bids on account of amendments / corrigendum if any issued subsequent to the date of Notice Inviting Tender.

4.8.3. All the Bidders must periodically browse the above websites for any amendment or corrigendum issued in connection with this Tender. The Corporation

will not be responsible for the failure of the Tenderer to update or to have comprehensive understanding of the provisions of this tender document including the changes announced through the website.

4.9. Language of the Bid:

The bid prepared by the Bidder as well as all correspondence and documents relating to the bid shall be written in English language. Documents not legible / readable shall not be considered.

4.10. Non Transferability:

The Tender form sold to a Tenderer is not transferable. It shall not be used by others and if used by others it will be rejected. Similarly photo copy of the tender form will be rejected.

4. 11. Downloading of Tender Document :

4.11.1. The tender document can be downloaded from the website www.tenders.tn.gov.in (or) www.textbookcorp.tn.gov.in on A4 size paper and computer print alone should be submitted in the form of a booklet. Submission of tender document in any other form will be summarily rejected.

4.11.2. The Tenderer shall download corrigendum/amendment/clarifications, if any, published subsequently and submit along with the tender. Otherwise the tender will be summarily rejected. It is the responsibility of the Tenderer to check and have knowledge of any corrigendum/amendment/clarifications issued and uploaded on the website of Corporation.

4.11.3. The Tenderer shall download tender documents in original without any change / addition / deletion and correction. If any change / addition / deletion are detected at any stage after the award of the tender, the EMD as well as Security Deposit remitted by the Tenderer will be forfeited without any intimation and the Tenderer will also be blacklisted from participating in the subsequent tenders. Besides such Tenderers are liable to be prosecuted.

4.12. Cost of Tendering

The Tenderer shall bear all costs associated with the preparation and

submission of tender and the Corporation shall in no case be responsible or liable for the costs of tendering incurred by the Tenderer, irrespective of the outcome of the tenders.

4.13. Bid Validity

4.13.1. Bid shall remain valid for a period of **Ninety days (90days)** after the deadline date for bid submission specified. A bid valid for a shorter period shall be rejected by the Corporation as non-responsive.

4.13.2. In exceptional circumstances, the Corporation may request the bidders to extend the period of validity for a specified additional period. The request and the bidder's responses shall be made in writing or e-mail. A bidder may refuse the request without forfeiting his bid security (EMD). A bidder agreeing to the request will not be required or permitted to modify his bid, but will be required to extend the validity of his bid security for the period of extension.

4.14. Earnest Money Deposit (EMD)

4.14.1. An Earnest Money Deposit of **Rs.1,20,000/- (Rupees One lakh and twenty thousand only)** shall be paid along with the Technical Bid by way of Demand Draft /Banker's Cheque obtained from a Nationalized / Scheduled Bank drawn in favour of **Tamil Nadu Textbook and Educational Services Corporation, Chennai-6** payable at Chennai. As per the provision under Rule 14(1) of Tamil Nadu Transparency in Tender Rules 2000 any category of tenderers specifically exempted by the Government from the payment of EMD are not required to make the deposit along with the bid. Necessary proof for exempting EMD should be enclosed.

4.14.2. The amount of the Earnest Money Deposit submitted by the unsuccessful Tenderers will be returned through ECS mode to Bank account mentioned in the Profile of the Tenderer, after the award of the Contract pursuant to the selection of the successful Tenderer. The Earnest Money Deposit amount held by the Corporation will not fetch any interest till it is refunded to the unsuccessful Tenderers.

4.14.3. The Earnest Money Deposit amount of the successful Tenderer(s) can be adjusted against the Security Deposit (SD) payable for ensuring successful

execution of the Contract.

4.14.4. Any tender not accompanied by Demand Draft or Banker's Cheque towards Earnest Money Deposit as in Sub-Clause (1) above shall be summarily rejected by the Corporation. If any tenderer claims exemption of EMD, necessary document for such exemption should be enclosed, failing which the tenderer will be summarily rejected.

4.14.5. The Earnest Money Deposit amount shall be forfeited.

- (a) If a Tenderer withdraws the tender after opening of Technical Bid during the validity period specified in the tender document.
- (b) In the case of a successful Bidder, if the bidder fails to sign the agreement or to remit the Security Deposit within the specified time limit.
- (c) If the bidder does not accept the correction of the bid price pursuant to clause 4.24.1.

4.14.6. Further the Corporation will blacklist the Successful Tenderer without prejudice to any action that may be taken against the Successful Tenderer, in addition to Tender clause 4.14.5.

4.15.Submission of Tender :

4.15.1. Submission of Tender in Two Cover System:

Tender shall be submitted in two covers original i.e Part-A and Part-B. The Part-A cover shall contain the EMD & Technical Bid as per clause 4.15.2 and superscribed on the cover as "Part-'A'- Technical Bid"- "Tender for Supply and delivery of **Wooden Colour Pencil (Bi-Colour)** on annual rate contract basis". On the Part-A Cover, the Name and Address of the Tenderer should be written and sealed. **The tender document shall compulsorily be spiral bound & indexed with page numbers.**

The Part-B Cover shall contain the Price-Bid- superscribed on the cover as "Part-'B'- Price Bid" -"Tender for Supply and delivery of **Wooden Colour Pencil (Bi-Colour)** on annual rate contract basis" for the year 2022 – 2023. On the Part B Cover, the Name and Address of the Tenderer shall be written and sealed.

Both the Covers i.e., Part-A and Part-B should be put in a cover superscribing thereon "**Tender for the Supply and delivery of Wooden Colour Pencil (Bi-Colour) on annual rate contract basis for the year 2022 – 2023**" and the Name and

Address of the Tenderer shall be written on that cover and it shall be sealed. The sealed cover addressed to the Tender Inviting Authority i.e. the Managing Director, Tamil Nadu Textbook and Educational Services Corporation shall be put in the box kept in the office of the Corporation within the scheduled time and date of submission of the Tender. It may also be sent by Post so as to reach the office of the Corporation within the stipulated time and date of submission of the Tender. But the Corporation shall not be responsible for any postal delay or delay due to any other means of communication. Belated submission of Tenders by the Tenderers or belated receipt of Tenders by the Corporation shall result in summary rejection of such Tenders. If the last date scheduled for submission of the tender happens to be a Government holiday for any reason, the sealed tenders may be submitted on the next working day before the appointed time. Tender once submitted shall not be permitted to be altered or amended.

4.15.2. Documents to be furnished in the Part – A Cover (Technical Bid):

- (a) Covering Letter
- (b) Letter of Tenderer duly signed by the authorized signatory in full with seal.
- (c) Other than the exempted case, Crossed Demand Draft towards EMD.
- (d) Annexure I to XII towards Drawings, Specifications and Declaration & Formats.
- (e) Profile of the Company with a Video CD covering the entire manufacturing process of the Company from the raw materials stage to the stage of finished products.
- (f) Letter of Authorization / Power of Attorney for signing the Tender Document on a Non-Judicial Stamp Paper of value of not less than Rs.100/-. In case of Public Sector Undertakings / Public / Private Limited Companies, Authorization from the appropriate authority to sign the tender document must be enclosed along with Technical Bid. Tenders received without such authorization shall be rejected.
- (g) I.T. Returns for the last 3 financial years from 2017-18 to 2019-20
(Self attested Photo copies to be enclosed).
- (h) GST Registration Certificate and PAN Card **(Self attested Photo Copies**

to be enclosed).

- (i) Audited Balance Sheet and Profit & Loss Accounts for the last 3 financial years from 2017-18 to 2019-20 (Self attested Photo copies to be enclosed).
- (j) All the required documents including Performance Certificate obtained from the Client for qualification criteria given in this tender along with other required documents and the enclosures as per the Check List shall be enclosed. **(Photo copies to be enclosed)**
- (k) List of Plant and Machinery and Laboratory Equipments available at the Tenderer's manufacturing unit for manufacturing the **Wooden Colour Pencil (Bi-Colour)** and for conducting the Tests as per the specifications in the Tender Document with full address of factory and office. **(self attested Photo copies & address proof for factory to be Notarized and enclosed)**
- (l) 3 Samples of **Wooden Colour Pencil (Bi-Colour)** boxes without any marking/printing should be furnished.
- (m) In case of tenderer being suppliers, the documents required in (e) and (k) shall be obtained from the manufacturer with whom the supplier has contracted, and furnished by the supplier.

4.15.3. Details to be furnished in the Part- B (Price Bid) cover :

- (a) Covering Letter.
- (b) Price Bid for the work with each page signed, dated and stamped with the seal of the firm.
- (c) The offer shall be unconditional.
- (d) The price quoted shall be inclusive be all and no additional claim on any ground shall be entertained.
- (e) Apart from the Schedule of Prices duly filled in, the Bidders shall not enclose any other documents or statements that influence the price except Discount/Rebate letter. In such an event, the Corporation shall summarily disqualify the Bidder and reject the Bid.

4.15.4. Signing of Tender

a) The tender shall be typed or written legibly in indelible ink and shall be signed by the Tenderer or a person duly authorized to bind the Tenderer to the contract. **All pages of the tender shall be signed by the Tenderer or person(s) authorized to sign the Tender with the seal.**

b) The tender shall contain no alterations or additions, except those to comply with instructions issued by the Corporation or as necessary to correct errors made by the tenderer, in which case such corrections shall be initialled by the person or persons signing the tender.

4.16. Extension of Period of Contract

The Managing Director of this Corporation may extend the validity period for further one year on the same terms and conditions with the settled rate of the **Wooden Colour Pencil (Bi-Colour).**

4.17. Mode of Submission of Samples

4.17.1. The Tenderers shall submit **three boxes of samples of Wooden Colour Pencil (Bi-Colour)** without any markings/printing, manufactured as per the specifications given in the Tender Document along with Part- A Cover (Technical Bid) for testing. Received Samples shall not be returned under any circumstances.

4.17.2. Tenders received without samples or with markings shall also be summarily rejected.

4.18. Modification and Withdrawal of Tenders:

4.18.1. Tenderers may modify or withdraw their tenders by giving notice in writing before the due date for submission.

4.18.2. The modification or withdrawal notice shall be prepared, sealed, marked and delivered in accordance with clause 4.15, with the outer and inner covers additionally marked "MODIFICATION" or "WITHDRAWAL" as appropriate.

4.18.3. No tenderer shall be allowed to withdraw/modify the tenders after the last date of submission of the tender.

4.18.4. Withdrawal or modification of tender between the deadline for submission of tenders and the expiration of the original period of validity specified or as extended period may result in forfeiture of the EMD.

4.19. Opening of Tenders:

4.19.1. Tenders will be opened at the scheduled date and time in the office of the Corporation in the presence of the Tenderers or their representatives who are authorised to represent the Tenderers. **The representatives of Tenderers who attend the Tender opening shall produce the proof of their identity and the authorization letter from the Tenderers.** Only one representative is permitted to attend for both technical and price bid opening of the tender on behalf of the Tenderer.

4.19.2. Tenders received after the due date and time will not be considered. Tenders in unsealed cover or Tenders which are not signed in each page or in incomplete shape or through facsimile (Fax) or by electronic mail or through any other manner which is not in accordance with the instructions specified in the Tender will not be accepted.

4.19.3. Covers marked "WITHDRAWAL" shall be opened and readout first and their tender shall not be opened. Subsequently, all covers marked "MODIFICATION" shall be opened and the submission therein shall be read out.

4.19.4. If the day fixed for opening of the tender happens to be a Government holiday for any reason, the sealed tenders shall be opened on the next working day at the appointed time.

4.19.5. Part- A cover containing Technical Bid shall be opened first. The supporting documents shall be cross-checked wherever required.

4.20. Criteria for Evaluation of Technical Bid:

Any Tender not containing the required documents and not fulfilling the qualification criteria indicated in the Tender document shall be summarily rejected.

4.20.1. Prior to the detailed evaluation of bids, the Corporation will determine whether each Bid (a) meets the eligibility criteria (b) has been properly signed (c) is accompanied by the required EMD and (d) is substantially responsive to the requirements of the Bidding documents.

4.20.2. A substantially responsive bid is one which conforms to all the terms, conditions, and specifications of the tender documents, without material deviation. A material deviation or reservation is one (a) which affects in any substantial way the

scope, quality, or performance of the supply; (b) which limits in any substantial way, inconsistent with the tender documents, the Corporation rights or the Bidder's obligations under the contract; or (c) whose rectification would affect unfairly the competitive position of other bidders presenting substantially responsive bids.

4.21. Sample Testing for Tender Evaluation:

4.21.1. The Tenderer, while submitting the tender documents, shall submit 3 samples of **Wooden Colour Pencil (Bi-Colour)** boxes, without any markings/printings, manufactured as per technical specifications in the tender document. The samples shall be tested by the Corporation in an accredited laboratory. The testing of such samples submitted by the Tenderers shall be conducted to check whether the quality, size, dimension and measurement of the samples are in conformity with the Technical specifications and other test parameters prescribed in the Tender document.

4.21.2. The Corporation reserves the right to test the samples at its discretion and in the event of failure of the sample in the test, the tender shall be summarily rejected.

4.22. Site Visit:

4.22.1. On receipt of samples along with the technical bids. the authorized representative of the Corporation shall visit the manufacturing units of the tenderers to verify the manufacturing capacity, the availability of the plant, machinery and manpower, the infrastructure facility including the quality testing, financial aspects, i.e, Profit & Loss account, Balance Sheet, IT returns, Turnover etc. Further the authorised representative shall inspect the original Certificates of Registration and Incorporation of the Company and the originals of all the relevant documents which the Tenderers filed along with the Tender. Mere site visit alone will not be construed as their eligibility. In case of suppliers, in addition to the scrutiny of the above financial aspects such as Profit & Loss accounts, Balance sheets etc. the manufacturing activities of the manufacturer with whom the supplier has contracted shall be inspected.

4.22.2. The site visit will be made only to the manufacturing units as mentioned in the profile of the Tender documents in Annexure – IV Any factory / manufacturing unit located anywhere other than the address mentioned in the

profile of the Tender document will not be considered for evaluation.

4.22.3. If the report of the Field Inspection / Site Visit is adverse, the Tenderer shall be disqualified and the Price Bid of such Tenderer shall not be opened.

4.23. Opening of Price Bid (Part - B Cover) :

4.23.1. Only the Price Bids of the Tenderers who are qualified in the Technical Bid shall be opened.

4.23.2. The date, time and venue of opening of Part - B Cover i.e. Price Bid will be intimated separately to the qualified eligible Tenderers.

4.23.3. The Price Bid will be opened on the intimated date and time in the presence of the qualified eligible Tenderers or their authorised representatives. The date and time of opening will be communicated via e-mail / post.

4.24. Evaluation of the Price Bid:

The Price Bid of the technically responsive tenders shall be evaluated and compared in accordance with the criteria specified. In the evaluation of the Price Bid, the following procedure shall be adopted as per Tamil Nadu Transparency in Tenders Act, 1998 and Tamil Nadu Transparency in Tenders Rules, 2000.

4.24.1. In determining the lowest evaluated price, the following factors shall be considered.

- a) the quoted price shall be corrected for arithmetical errors.
- b) in case of discrepancy between the prices quoted in words and in figures, lower of the two shall be considered.
- c) where there is a discrepancy between the unit and the line item total resulting from multiplying the unit rate by the quantity, the unit rate as quoted will govern,
- d) In the evaluation of the price of the goods which are subject to SGST, CGST and IGST, the price shall be determined as inclusive of such SGST, CGST and IGST.
- e) the amount stated in the bid will be adjusted by the Corporation in accordance with the above procedure for the correction of errors and shall be considered as binding upon the bidder. If the bidder does not accept the corrected amount the bid will be rejected and the EMD will be forfeited.

- f) Provided that where more than one Tender is submitted by the same tenderer, the lowest eligible financial tender shall be considered for evaluation.

4.24.2. The Corporation is empowered to negotiate with the L1 Tenderer(s). In case where two or more tenderers quoted the same price, the Corporation shall negotiate with L1 bidders & if necessary arrive at final negotiated price for supply and delivery of **Wooden Colour Pencil (Bi-Colour)** by entering into a rate contract.

4.24.3. In case where the quantity offered at the lowest price is less than the total quantity required, the Corporation after placing orders with the lowest evaluated tenderer for the entire quantity offered by such tenderer, subject to the ability to supply, adopt the following procedure to procure the balance quantity :-

- i) Negotiate with the next lowest Tenderers in strict ascending order of evaluated price and require to match the price offered by the lowest evaluated tenderer and place orders until the entire quantity required is ordered; or
- ii) Require all the other eligible Tenderers who participated in the Tender and offered a price higher than that offered by the lowest evaluated tenderer, to submit sealed offers of the quantity they would be willing to supply at the price quoted by the lowest evaluated tenderer, and there after place orders for the remaining required quantity with all those who match the lowest evaluated price such that those who bid lower prices in the original tender get a higher priority for supply.

4.24.4. The total quantity of the **Wooden Colour Pencil (Bi-Colour)** to be ordered and procured may be apportioned among the bidders who matches the L1 negotiated rate.

4.24.5. Where the Corporation deems fit, it may issue an advertisement indicating the rates fixed and call for enrolment of more suppliers at the L1 rate subject to such suppliers fulfilling the eligibility criteria.

4.25. Approval of the Contract by the Board of Governors of the Corporation:

The Contract shall be awarded only with the approval of the Board of Governors to the successful L1 Tenderer(s) with whom negotiations were made. The apportionment of the bulk quantity of the goods to be procured as specified in

Clause 4.24.3 and 4.24.4 above shall be done only with the approval of the Board of Governors based on the manufacturing capacity.

4.26. Right to Accept / Reject any or all Bids:

The Tender Accepting Authority i.e the Board of Governors of the Corporation reserves the right to accept or reject any or all of the tenders including the lowest in full or in part without assigning any reasons thereof and without thereby incurring any liability to the Bidder or Bidders who may be affected financially or otherwise to this effect.

4.27. Letter of Acceptance:

The Managing Director of the Corporation shall issue the Letter of Acceptance to the successful Tenderer(s).

4.28. Payment of Security Deposit (SD):

4.28.1. The Successful Tenderer shall be required to furnish Security Deposit equivalent to 5% (Five percent) of the value of the purchase order as a guarantee for the performance of the Contract. The EMD will be adjusted against the Security Deposit. After adjusting the EMD, the successful Tenderer shall pay the balance amount through **Demand Draft within 7 days from the date of issue of Letter of Acceptance.** The Demand Draft shall be obtained from any one of the Nationalized Banks / Scheduled Banks drawn in favour of **Tamil Nadu Textbook and Educational Services Corporation, Chennai - 600 006** payable at Chennai or in the form of unconditional irrevocable Bank Guarantee valid for **24 months.** Failure of the successful bidder to furnish the security deposit shall constitute sufficient grounds for cancellation of the award and forfeiture of the EMD. **Exemption from payment of Security Deposit will not be allowed under any circumstances.**

4.28.2. The Security Deposit shall be released to the successful Tenderer after the performance of the Contract in full without deficiency or default and to the entire satisfaction of the Tamil Nadu Textbook and Educational Services Corporation and on completion of the warranty period of 6 months post supply. The Security Deposit so held by the Corporation, shall not earn any interest till it is released to the Successful Tenderer. The release of the Security Deposit is subject to the forfeiture clauses in the Tender Document.

4.28.3. The Security Deposit shall be forfeited if the Successful Tenderer fails to execute the agreement within the stipulated time or fails to perform the contract or part of the contract. The Security Deposit shall also be liable for forfeiture for violation of any of the tender conditions or for the failure to supply the ordered quantity of goods in full properly and promptly.

4.29. Execution of Agreement:

4.29.1. The successful Tenderer shall execute the Agreement for the fulfillment of the Contract on a Non-Judicial Stamp Paper to the value of Rs.100/- **within 7 days from the date of issue of the Letter of Acceptance of the Contract.** The Agreement shall be part and parcel of the Contract and binding on the Corporation and the Successful Tenderer. In case of any difference or contradiction in the recitals in the Tender Document and the Agreement, the recitals in the Agreement shall prevail over those in the Tender Document.

4.29.2. The Successful Tenderer shall not assign or make over the Contract, the benefit or burden thereof to any other person or persons or Body Corporate for the execution of the Contract or any part thereof.

4.30. Interpretation:

If any question / doubt arise with reference to the interpretation of any provisions of the Tender Document, the decision of the Managing Director of the Corporation shall be final and binding.

4.31. Corrupt and Fraudulent practices:

The Corporation requires that Bidders observe the highest standard of ethics during the evaluation and execution of supply.

4.31.1.In pursuance of this policy, the Corporation defines for the purposes of this provision the terms set forth below as follows:

- (i) 'Corrupt practice' mean offering, giving, receiving or soliciting of anything of value to influence the action of a public official in the evaluation process or in contract execution.
- (ii) 'Fraudulent practices' means a misrepresentation of facts in order to influence the evaluation process or execution of a contract / supply to the detriment of the Corporation and includes collusive practice among bidders (prior to or after bid submission) designed to establish bid prices at artificial,

non competitive levels and to deprive the Corporation of the benefits of free and open competition.

4.31.2. Will reject a proposal for award if it determines that the Bidder recommended for award has engaged in corrupt or fraudulent practices in competing for the contract in question.

4.31.3. Will declare a firm ineligible either indefinitely or for a stated period of time to be awarded a contract if it any time determines that the firm has engaged in corrupt and fraudulent practices in competing for or in executing the contract.

5. TERMS AND CONDITIONS OF THE TENDER

5.1. The Terms and Conditions of the Tender shall supplement the “INSTRUCTIONS TO THE BIDDERS”.

5.2. The time and date of supply and delivery of **Wooden Colour Pencil (Bi-Colour)** stipulated in the purchase order shall be deemed to be the essence of the Contract.

5.3. Release of Purchase Order :

Purchase Order shall be issued to the successful bidder only after the Security Deposit is paid as per **clause 4.28** and agreement is executed, with Tamil Nadu Textbook and Educational Services Corporation as per **clause 4.29** of Instruction to Bidders and accepting the samples as mentioned in the clause 5.4.1. of Terms and Conditions of the Tender.

5.4. Technical Specifications:

The **Wooden Colour Pencil (Bi-Colour)** supplied by the Successful Tenderer shall conform to the technical specifications in **Annexure I, II (a)&(b) and III** of the Tender Document.

5.4.1. Sample Acceptance

The Successful Tenderer shall submit untested samples of three boxes of **Wooden Colour Pencil (Bi-Colour)** (i.e.) finished products manufactured as required in Letter of Acceptance with technical specifications in the Tender Document to the Corporation within 7 days from the date of Letter of Acceptance. The samples will be verified for the visual appearance and dimensions. After getting the sample acceptance letter and purchase order, the tenderer shall commence the bulk production.

5.5 Supply:

5.5.1. Supply all the ordered **Wooden Colour Pencil (Bi-Colour)** commensurate with the technical specifications in **Annexure I to III** and the specifications of the Model of **Wooden Colour Pencil (Bi-Colour)** prescribed in **Annexure II (a) & (b) and III** shall be made *within sixty days* from the date of

issue of purchase order or date of acceptance of samples whichever is later. The entire supply shall be completed within the time schedule at the negotiated rates specified in the purchase order.

5.5.2. The entire quantity of the quality **Wooden Colour Pencil (Bi-Colour)** shall be delivered at the designated locations in each Block Head Quarters of each District in the State of Tamil Nadu in good condition. The transit / Freight Charges, Insurance, all the Taxes, loading and unloading charges and all other incidental charges for the supply and delivery of the ordered goods in good condition to the designated locations shall be borne by the Successful Tenderer at his risk and cost.

5.5.3. The rejected quantity during Pre Inspection testing by the inspection authorities should not be mixed with the cleared quantity for supply and should be kept separately in the manufacture premises of the supplier. While claiming payment the supplier shall enclose a certificate to the effect that the quantity rejected during the pre-inspection was isolated separately and not mixed with the cleared quantity. The Third Party Inspection Agency (TPIA) who are appointed as pre inspection and testing agency should also verify whether the above procedure has been strictly followed by the supplier.

5.5.4. If the successful Tenderer is from outside the State of Tamil Nadu the Tenderer should set up a local office in Chennai to ensure service. The address of the local office and the details of the responsible person in the local office should be informed to the Corporation before commencing the supply of **Wooden Colour Pencil (Bi-Colour)**.

5.6 Sample Selection and Testing:

5.6.1 Pre - Despatch Inspection:

(a) Pre-Despatch Inspections will be conducted at the premises of the Successful Tenderer's manufacturing units as specified in the tender document (Annexure – IV). The samples shall conform to the requirements of quality, colour, shade, size, dimension and weight as stipulated in the **Annexure I, II (a) & (b) and III)** of the tender document. If the sample fails the lab test, the entire lot from which the sample was drawn shall be rejected.

(b) The Successful Tenderer shall inform the Corporation through e-mail or in

writing about the date of readiness of the supplies for the purpose of Inspection (i.e.quantity etc).

(c) 50 samples from a lot of 10,000 Boxes of **Wooden Colour Pencil (Bi-Colour)**, 3 samples from the 50 samples shall be taken and subjected to the lab test. Clearance will be issued by the Corporation, based on the lab test report, to the tenderer for commencing the despatch accordingly.

d) The cost of all the above tests including the freight charges, traveling expenses and incidental expenses shall be borne by the successful Tenderer.

e) If any substandard raw materials are found to be used by the successful Tenderer, the Corporation without prejudice to any other action that may be taken against the successful Tenderer shall terminate the Contract.

5.6.2 After Supply:

a) It shall be the responsibility of the successful Tenderer to ensure that the **Wooden Colour Pencil (Bi-Colour)** supplied and delivered by him are in good condition.

b) Random samples (5 samples per district) of the **Wooden Colour Pencil (Bi-Colour)** supplied shall be tested in an accredited laboratory by the Corporation for its suitability and utility with reference to the specifications given in **Annexure I, II (a) & (b) and III)**. The dated acknowledgement for the delivery of the **Wooden Colour Pencil (Bi-Colour)** to the designated locations should be obtained from the respective Block Educational Officers / District Educational Officers.

c) The testing charges for the pre-inspection and post delivery samples have to be borne by the successful Tenderer. The total inspection and sample testing charges for pre and post supply shall be deducted from the bill of the successful Tenderer.

5.7. Insurance:

The delivery of the quality tested goods in fully packed and labeled condition as per the statutory norms and the specifications given in the Tender Document to the designated destinations in time shall be the responsibility of the successful Tenderer. The transit loss / theft / pilferage/ damage of the goods under any circumstance shall be the liability of the successful Tenderer.

Insurance and transit insurance of the goods shall be the liability of the successful Tenderer.

5.8. Packing and Labeling:

5.8.1. 6 Pieces of **Wooden Colour Pencils (Bi-Colour)** shall be packed in two rows in Carton Box of appropriate size.

5.8.2. 32 Boxes of **Wooden Colour Pencil (Bi-Colour)** shall be packed in a corrugated box with sufficient buffer to avoid any breakage during transit.

5.8.3. Each corrugated box shall be labelled and the label shall contain the following: NOT FOR SALE, SCHEME OF SUPPLY OF COST-FREE **WOODEN COLOUR PENCIL (BI-COLOUR)** TO SCHOOL CHILDREN by the Department of School Education, Government of Tamil Nadu, successful Tenderer's Company Code No., Quantity, Serial Number and the Date, Month and Year of manufacturing of the **Wooden Colour Pencil (Bi-Colour)**.

5.9 Warranty and Replacement

i. Warranty

The warranty of the **Wooden Colour Pencil (Bi-Colour)** supplied by the Successful Tenderer shall be for a period of **six months** from the date of distribution of the same to the school children in each block in each District in Tamil Nadu. The Successful Tenderer shall replace the defective **Wooden Colour Pencil (Bi-Colour)** supplied by him with new one at his cost at the designated points during the period of Warranty.

Defects in the Wooden Colour Pencil (Bi-Colour), if any indicated in the feedback obtained from beneficiary student through the respective DEOs / BEOs shall be replaced.

ii) Replacement :

a) The quality of **Wooden Colour Pencil (Bi-Colour)** supplied by the successful Tenderer shall be in accordance with the Specifications as in the **Annexure I, II (a) & (b) and III)**. If any defect is found in the post-delivery tests in any one or more of the five samples, the entire lot supplied to the particular DEO/BEO will be treated as defective and shall have to be replaced. The quantity to be replaced shall also be subjected to pre-inspection test in the manufacturer premises and the same shall be with in the stipulated time.

b) In addition, in case of supply of **Wooden Colour Pencils (Bi-colour)** if a particular pieces of a box is found defective, entire box (Wooden Colour Pencils (Bi-colour)) consisting of all the pieces shall be replaced.

5.10.Payment Terms :

5.10.1. No advance payment shall be made.

5.10.2. The successful Tenderer shall raise the bill only after completion of supply and delivery in all the Blocks/ Offices in each District as per the delivery schedule as a whole in bulk. No Bill shall be admitted from the successful Tenderer who fails to effect the supply and delivery of the **Wooden Colour Pencil (Bi-Colour)** to all the Block Offices in each District as per the Purchase order in time.

5.10.3. The bill raised by the successful Tenderer shall have all Registration Numbers printed on the Bill. The validity of the Tax Registration during the currency period of the Contract shall be the sole responsibility of the successful Tenderer.

5.10.4. The successful Tenderer shall submit the delivery reports along with delivery challan signed by the concerned DEOs / BEOs with legible dated acknowledgement duly affixed with proper seal along with a rejected quantity separation certificate as specified in tender clause 5.5.3. The Corporation shall process the bill for payment of **80%** of the bill only after completion of the supply of the entire quantity in a District. Based on the certificates issued by the Block Educational Officers / District Education Officers and after the receipt of certificate of the testing of the random samples of the supplied **Wooden Colour Pencil (Bi-Colour)** issued by an accredited laboratory specified in Clause **5.6.2. Terms and Conditions of the Tender**, the bills will be admitted. The Corporation shall settle 80% of the bill within a reasonable time after receipt of the hard copy of the delivery notes and the afore-said Certificates of Acceptance and Lab Tests. All the payments will be made through ECS to the supplier's bank account declared by him at the time of execution of agreement.

5.10.5. Out of the remaining **20%** of the bill, **15%** of the bill shall be settled after the effective performance of the Contract in full to the entire satisfaction of the Corporation, duly deducting the Pre-Inspection Testing and Post Sample Testing, Penalty and other charges if any.

5.10.6. The Corporation shall recover any dues from the Successful Tenderer if found to be recoverable on a later date in the audit even after final settlement of the Bill. The Successful Tenderer shall be liable to pay such dues to the Corporation.

5.10.7. The remaining **5%** of the Bill shall be paid after six months from the date of complete supply and distribution of the ordered quantity of **Wooden Colour Pencil (Bi-Colour)** to the School Children in each Block and in each District as per the Purchase Order and the Delivery Schedule.

5.11. Liquidated Damages and Penalty:

5.11.1. Penalty:

(a) If the Successful Tenderer fails to deliver the **Wooden Colour Pencil (Bi-Colour)** as per the Purchase Order and the Delivery Schedule specified by the Corporation, the Corporation shall have the right to impose **penalty of 1%** of the value of the delayed supply with applicable GST (which includes the date of rectification/replacement of defective goods) for every week of delay or part thereof after the due date of delivery for a period of **Two weeks** and thereafter at the rate of **3%** of the value of the delayed supply with applicable GST **for each Week of delay** or part till completion. Maximum penalty shall be limited to 10% of the total contract value. The Corporation shall have the right to make purchase from outside at higher rates if the delay continues even after a period of four weeks for which penalty is imposed on the Successful Tenderer and the loss sustained by the Corporation to this effect shall be deducted from the bill of the Successful Tenderer and / or from the Security Deposit of the Successful Tenderer .

(b) In respect of replacement / rectification of goods, the date of replacement / rectification will be taken as actual date of supply. In such cases, the ordered quantity of goods for that location where the replacement / rectification were made will be taken for calculation of penalty for delay.

Liquidated Damages

5.11.2. The Corporation shall have the right to terminate the Contract of the Successful Tenderer who fails to deliver the **Wooden Colour Pencil (Bi-Colour)** in full as per the Purchase Order and the Delivery Schedule.

5.11.3. The Corporation shall have the right to place the Purchase Order with the other eligible Tenderer(s) if the supply is delayed beyond four weeks after the due date and it shall be at the cost and consequences of the Successful Tenderer who is in default. The Corporation also reserves the right to take any other action against the Successful Tenderer in default for the loss and the consequential loss sustained by the Corporation.

5.11.4. If the delay continues even after a period of 50% of original supply period, the contract is liable to be cancelled at the discretion of the Managing Director in addition to imposing of a penalty of 5% of the value of delayed supply with applicable GST irrespective of the 10% of penalty already provided for in **clause 5.11.1** of the terms and conditions of the Tender.

5.11.5. The Successful Tenderer shall not manufacture, market, sell or supply the **Wooden Colour Pencil (Bi-Colour)** manufactured, packed and labeled as per the Technical specifications in the Tender Document exclusively for distribution among the School Children studying in Government and Aided schools in Tamil Nadu. The Corporation shall impose penalty of not less than Rs.5,00,000/- (Rupees Five Lakh Only) every time for violation of the aforesaid condition. The penalty shall be in addition to the Civil and Criminal action taken by the Corporation against such Successful Tenderers in default. The Corporation shall have the right to blacklist such Successful Tenderers from participating in the subsequent Tenders of the Corporation for a minimum period of three years.

5.11.6. The Corporation shall have the right to blacklist the Successful Tenderer for breach of any conditions and Terms of the Tender / Agreement at any point of time.

5.11.7. If at any time before the acceptance of tender, the Tender Accepting Authority receives information that a tenderer who has submitted tender has been banned by any Procuring Entity, the Corporation shall not accept the tender of the tenderer even if it may be the lowest tender.

5.12 Termination of Contract :

5.12.1. Termination for Default:

- a) The Corporation may, without prejudice to any other remedy for breach of Contract by the Successful Tenderer, terminate the Contract in whole or part,

by a 15 days' written notice of breach of Contract to the Successful Tenderer,

- i. if the Successful Tenderer fails to deliver any or all of the goods within the time schedule specified in the Purchase Order, or within any extension thereof granted by the Corporation,
- ii. if the Successful Tenderer fails to perform any of the obligation(s) under the Contract;
- iii. if the Successful Tenderer is found to have involved in fraudulent, corrupt and unfair practices in competing for or in executing the Contract.

If the Corporation terminates the Contract in whole or in part, the Corporation may procure, upon such terms and in such manner as it deems appropriate, the goods similar to those supplied and delivered and in that case the Successful Tenderer whose contract is terminated in whole or in part shall be liable to the Corporation for any additional costs involved in procuring and supplying the goods to the designated destinations. However, the Successful Tenderer shall continue the performance of the Contract to the extent not terminated. The Corporation reserves the right to take further action against the Successful Tenderer whose Contract has been terminated in whole or in part.

5.12.2. Termination for Insolvency:

The Corporation may at any time terminate the Contract by giving 15 days' written notice to the Successful Tenderer without compensation to the Successful Tenderer and without incurring any liability if the Successful Tenderer becomes bankrupt or otherwise insolvent. Such termination shall not prejudice or affect any right of action or remedy that has accrued or will accrue thereafter to the Corporation.

5.12.3. Termination for Convenience:

The Corporation may terminate the Contract in whole or in part at any time during the validity period of the Contract for its convenience by giving 15 days' written notice and without compensation to the Successful Tenderer. The notice of termination shall specify that termination is for the Corporation's convenience, the extent to which the Contract is terminated, and the date upon which such termination becomes effective. The termination of the contract is without prejudice

to the penal consequences and damages for which the Successful Tenderer shall be liable for violation of the Contractual obligations.

5.13 Force Majeure:

5.13.1. Force Majeure means an event beyond the control of the Successful Tenderer and not involving the Successful Tenderer's fault of negligence and not foreseeable. Such event may include but are not limited to the acts of Nature such as fire, floods, epidemics, etc., and other events such as wars, revolutions, quarantine restrictions, etc.

5.13.2. If a Force Majeure situation arises, the Successful Tenderer shall promptly notify the Corporation of such conditions and the causes thereof through E-mail within 24 hrs of such event. The E-mail communication shall be followed by a report with documentary evidence to be sent to the Corporation within 3days from the date of occurrence of such event. Unless otherwise, directed by the Corporation in writing, the Successful Tenderer shall continue to perform his obligations under the Contract to a reasonably practical extent and shall seek all reasonable alternative means for effective performance of the Contract in time.

5.13.3. In the event of Force Majeure, the delivery period will be extended for a period equivalent to the period during which Force Majeure event was in existence. For this period the Successful Tenderer shall not be liable to pay penalty. Further if the performance in whole or part, of any obligation under this Contract is prevented or delayed by reason of Force Majeure for a period exceeding 21 days, the Corporation may at its option and discretion terminate the Contract.

5.13.4. The price quoted by the bidder and accepted by the Corporation shall remain fixed and firm during the extended period during which Force Majeure was in existence. Force Majeure shall not have any bearing on the price quoted by the Successful Tenderer in the Tender.

5.14. Appeal:

Any tenderer aggrieved by the order passed by the Tender Accepting Authority may appeal to the Government within ten days from the date of receipt of order.

5.15 Conciliation & Arbitration:

5.15.1. Conciliation:

If any dispute or difference arises between the Corporation and a Successful

Tenderer with regard to the Contractual obligations, the same shall be referred to a Conciliator and settled by conciliation as per the provisions of The Arbitration and Conciliation Act, 1996. The sole Conciliator shall be nominated by the Managing Director of the Corporation. Conciliatory efforts are mandatory in tune with the Alternative Disputes Resolution (ADR) process before invoking the Arbitration Clause. The Conciliator shall endeavor to conclude his proceedings within three weeks from the date of reference of a dispute or claim to him.

The venue of the conciliation shall be exclusively at Chennai and the language to be used in the conciliation proceedings shall be in English.

5.15.2. Arbitration:

In case of any dispute or difference arising between the Corporation and the Successful Tenderer relating to any matter arising out of or connected with the Contract which still remains unsettled even after Conciliation, such dispute or difference shall be referred to the sole Arbitrator nominated by the Managing Director of the Corporation. The Arbitral proceedings shall be conducted in accordance with the provisions of the Arbitration and Conciliation Act, 1996. If the Arbitrator for any reason has to discontinue the Arbitration before completion of the arbitral proceedings, the Managing Director of the Corporation shall nominate another eligible and suitable person as Arbitrator and such Arbitrator may continue the proceedings from the stage at which his predecessor has discontinued or may proceed de novo. The Arbitral Award shall be final and binding on both the Corporation and the Successful Tenderer. No part of the Contract shall be suspended by the Successful Tenderer on the ground of pendency of the Arbitral Proceedings.

The venue of Arbitration shall be exclusively at Chennai. The language to be used in the Arbitral proceedings shall be in English.

5.16 Jurisdiction:

The Courts in the City of Chennai exclusively shall have the jurisdiction to try any matter or dispute or reference between the Corporation and the Successful Tenderers arising out of the Contract.

6. LETTER OF THE TENDERER

To

The Managing Director
Tamil Nadu Textbook and Educational Services Corporation,
EVK SAMPATH MAALIGAI,
D.P.I. Campus
68,College Road,
Chennai – 600 006.
Tamil Nadu, India

Sir,

I / We do hereby tender / offer to the Tamil Nadu Textbook and Educational Services Corporation for the Supply and Delivery of **Wooden Colour Pencil (Bi-Colour)** to the School Children in Tamil Nadu on annual Rate Contract Basis conforming to the technical specifications and to the conditions stated in the annexed tender and specification and drawings attached here to.

I / We have carefully understood the conditions of tender, details of the materials to be supplied and the specifications and drawings with all the stipulations to which I / We agree to comply.

I / We hereby undertake to complete the delivery of goods at the designated places mentioned in the contract, within the time limit as specified by the Corporation.

I am / we are quite aware that quality of the materials and time of delivery are the essence of this tender and accordingly, I/we would adhere to the same.

I / We further agree that I / We would not withdraw this tender either in full or in part. If by chance, I/we have to withdraw the offer, I/we agree that the EMD paid will be forfeited by the Corporation, without any notice to me / us.

I / We affirm that in any previous tender to the Tamil Nadu Textbook and Educational Services Corporation, I/we have not committed any fraud by furnishing wrong information and the Corporation had not written to us alleging fraud in our transaction with the Corporation.

I / We further confirm that in case, any of the information noted above is found to be incorrect, I / We will be liable for any action under the terms of the tender / agreement including termination of the contract and forfeiture of the Earnest Money / Security Deposit.

I / We hereby undertake and agree to pay the Security Deposit as per the tender conditions within seven days from the date of issue of Letter of Acceptance.

I / We undertake to sign an agreement with the Corporation within seven days from the date of issue of Letter of Acceptance.

I / We further agree that the acceptance of the tender conditions would, by itself, constitute a valid and concluded contract binding on me/us, even if separate contract is not signed.

I / We further agree that in the event of my/our failing to deposit securities mentioned above or to produce the latest income tax and GST clearance certificate or to execute the agreement within a period of seven days as referred above, the EMD of **Rs.1,20,000/- (Rupees One lakh and twenty thousand only)** submitted along with the tender shall be forfeited by the Tamil Nadu Textbook and Educational Services Corporation and in addition, the Managing Director, Tamil Nadu Textbook and Educational Services Corporation, shall be entitled to cancel the contract and there upon arrange for any other person or persons to supply the materials herein before mentioned and I / We agree to be liable for all damages, losses, charges and expenses arising from or by reason of such failure on our part.

I / We hereby further agree and undertake that:

- a. In case, there is any defect found in the **Wooden Colour Pencil (Bi-Colour)** or in any part of the **Wooden Colour Pencil (Bi-Colour)** delivered, I/we undertake to replace the same by a new one.
- b. If the **Wooden Colour Pencil (Bi-Colour)** delivered is found to have even the slightest damage, due to any reason like in the process of transportation, the material will be replaced by a new one.

I / We hereby declare that I / We agree to do the various acts, deeds and things referred to herein, for enabling the Corporation to procure the **Wooden Colour Pencil (Bi-Colour)** conforming to specifications.

Having fully understood the tender conditions and the above undertaking in this letter, I/we sign thisDay ofat

Yours faithfully,

Authorized Signature :

Name & Title of Signatory :
.....

Name of the Bidder :

Address :

7. SPECIFICATIONS**ANNEXURE – I****TECHNICAL SPECIFICATIONS FOR WOODEN COLOUR PENCILS (BICOLOUR)
AS PER SPECIFICATIONS (2022 – 2023)**

Sl. No.	Property	Wooden Colour Pencils (Bicolour)
1	Each Pencils shall have	Two Colour
2	No. of Shades	12 Nos.
3	Colour (6 pencils)	1. White and Black 2. Sky Blue and Dark Blue 3. Green and Light Green 4. Red and Orange 5. Yellow and Pink 6. violet and Brown
4	Shape of the Pencil	Hexagonal and both end pre sharpened
5	Length of the Pencils(Two colour)	176 ± 2 mm
6	Diameter of the Colour Pencil	7.05 ± 0.2 mm
7	Length of the Pencils(Each colour)	87 ± 2 mm
8	Diameter of the Lead	2.8 ± 0.1 mm
9	Net weight of 6 Wooden Colour Pencils with a Sharpener	30.8 ± 3 gms Net weight of sharpener : 2.8 ± 0.3 gms Net weight of 6 Wooden Colour Pencils: 28 ± 3gms
10	Material	Rich of colour pigments bonded with wood
11	Other Items Sharpener	Length 29 ± 1 mm with Metal Blade and Metal Screw. Body of the sharpener shall be made of high quality polystyrene and the blade shall be made of high speed carbon sheet with rust resistant coating. There shall be no lead breakage or crumbling of lead.
12	Packing	6 Wooden Pencils with 12 shades of colour arranged in one row in a carton box and separate space should be provided for sharpener in the same box. Card Board thickness: 0.5 ± 0.05 mm

Note:

With all the above specifications, the Wooden Colour Pencils (Bicolour) should have the following performance features:

- Smooth and easy spread of colour.
- Colour of the Wooden Colour Pencils (Bicolour) should be printed for easy identification. Ex. White and Black, Sky Blue and Dark Blue.

8. DRAWINGS

ANNEXURE - II (a)

MODEL OF WOODEN COLOUR PENCIL (BI-COLOUR)
(3D Coloured Diagram with Specifications)



Shape - Hexagonal and both end pre sharpened

Material - Rich Colour Pigment bonded with wood

Length - 176 ± 2 mm

Diameter of the Pencils- 7.05 ± 0.2 mm

Diameter of the lead - 2.8 ± 0.1 mm

ANNEXURE – II (b)

MODEL OF SHARPENER

(Diagram with Specifications)

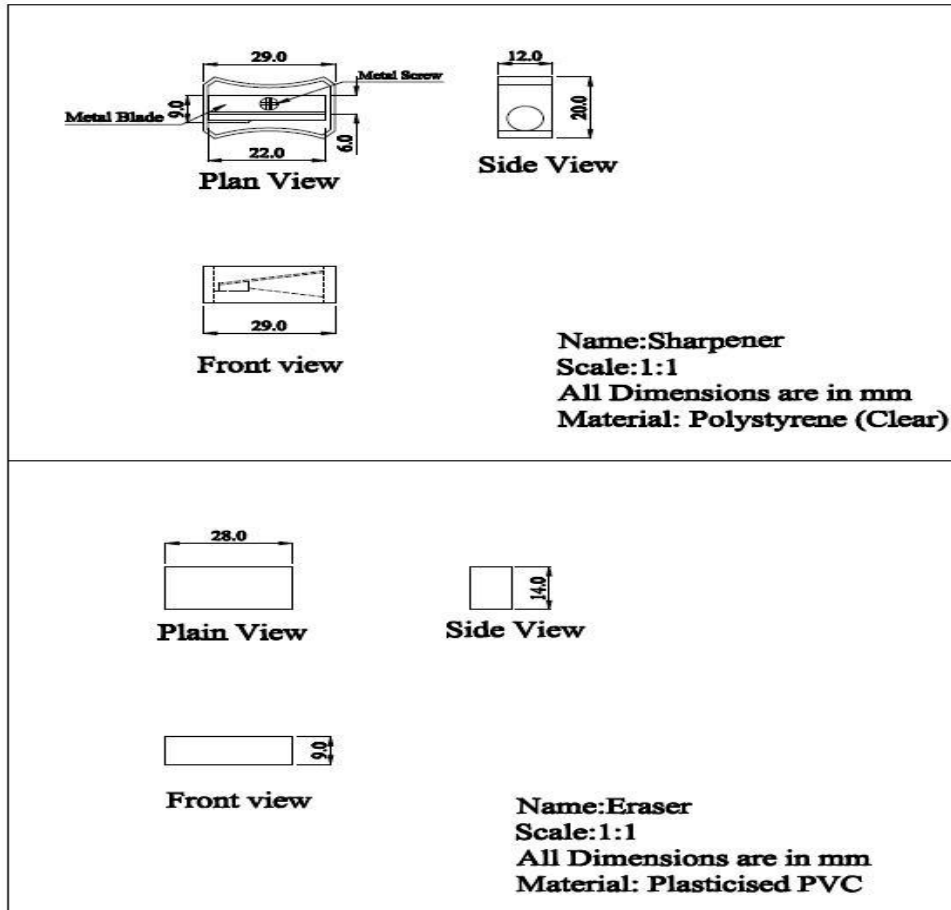

Body of Material – High Quality Polystyrene

Length – 29 ± 1 mm

Blade : Make of High speed Carbon sheet with
 rust resistant coating

ANNEXURE – III

**WOODEN COLOUR PENCILS (BICOLOUR) WITH SHARPNER
PACKING CARTON BOX DIMENSIONS (in mm)**

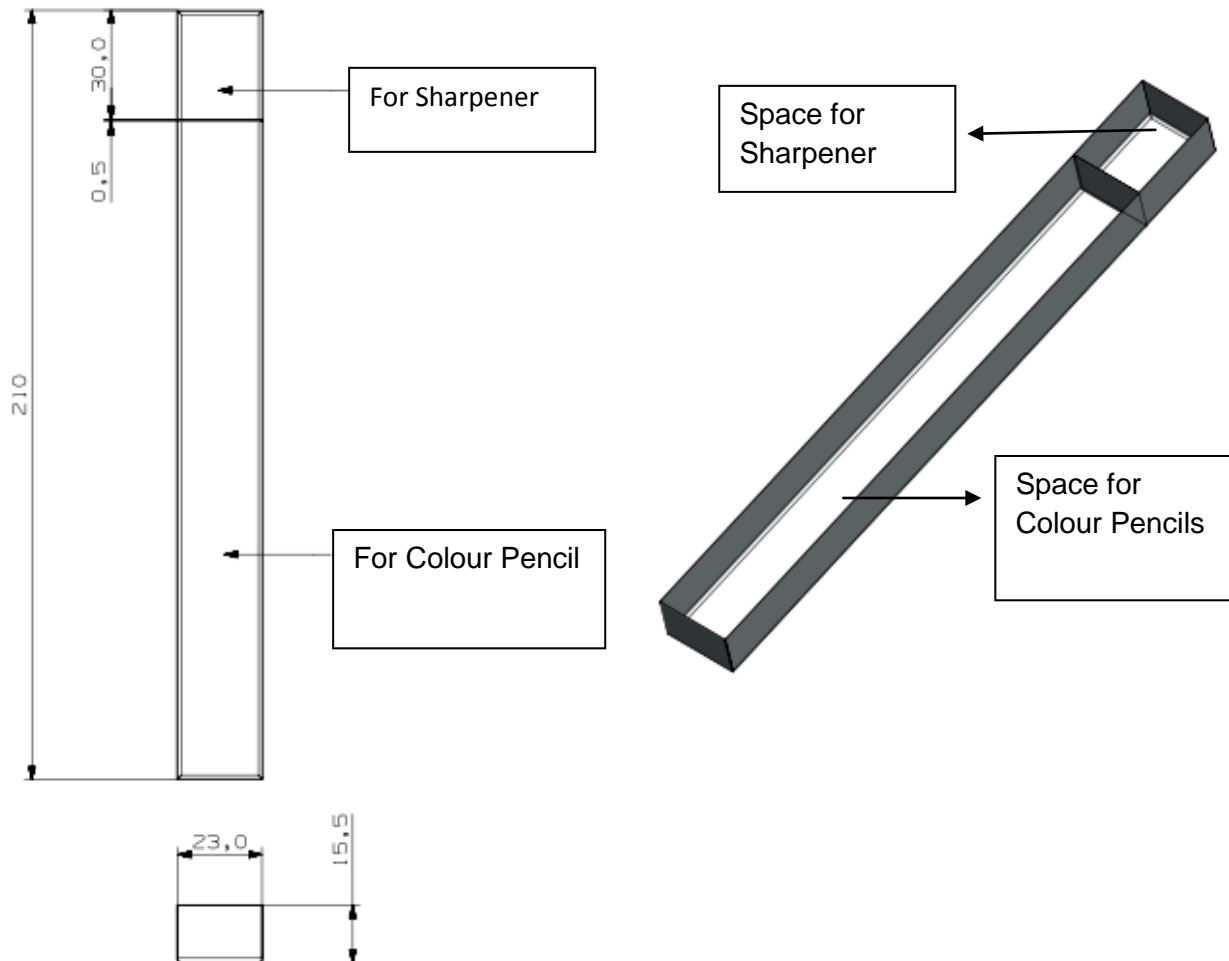

VIEW OF PACKING CARTON BOX IN OPEN CONDITION

DIMENSIONS (in mm)

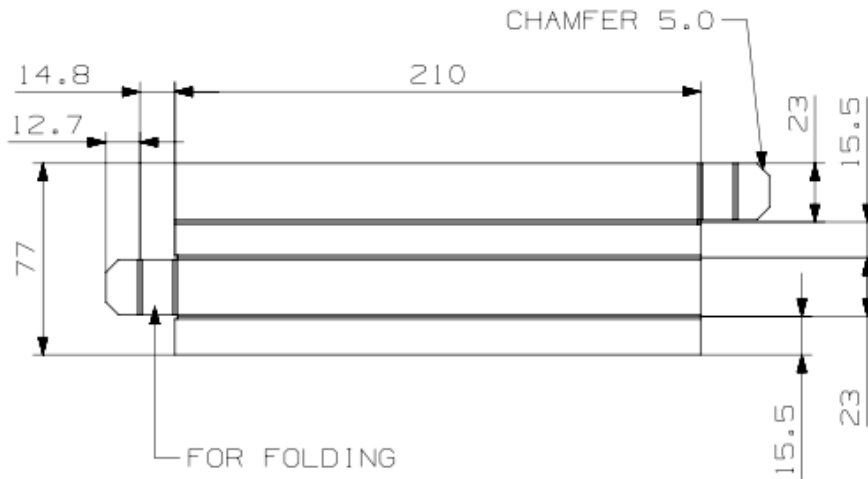

CARTON BOX AFTER FOLDING



BOX MODEL OF WOODEN COLOUR PENCILS (Bicolour) WITH SHARPNER

(3D Coloured Diagram with specifications)

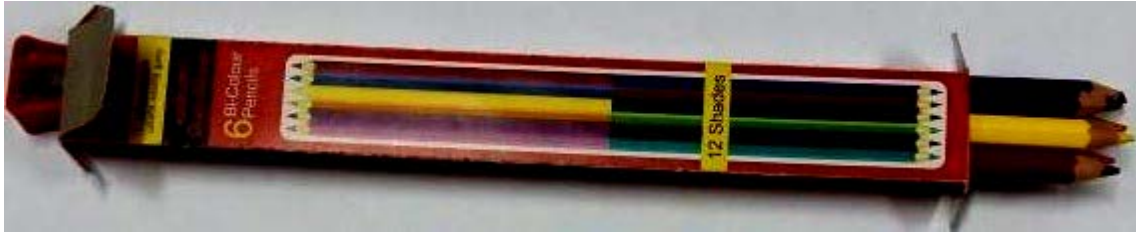

9. STATEMENTS, DECLARATIONS AND FORMATS**ANNEXURE – IV****PROFILE OF THE TENDERER**

The Tenderer shall furnish the following details without fail.

- a) Name of the Organization :
- b) Nature of the Organization :
(i.e. Public Sector Undertaking /
Public Ltd / Private Ltd Company/
Individual Proprietor /partnership
firm etc.,)
- c) Number and Year of Registration / :
Incorporation (Copy of Certificate of
Incorporation shall be enclosed)
- d) Address of the Registered Office of :
the Company with Phone, Fax, and
Email ID.
- e) Address of the Manufacturing Units :
with phone, Fax, and Email ID. In
case of supplier being the tenderer
the details of the manufacturer with
whom he has contracted may be
furnished.
- f) Audited annual report for the last :
three financial years (2017-18 to
2019-20):
(Copy of the same along with
Technical Bid shall be enclosed).
- g) A copy of PAN Card attested by the :
Company Secretary or Managing
Director or the Chartered Accountant
shall be enclosed.
- h) A copy of registration Certificate of :
GST attested by the Company
Secretary or Managing Director or
the Chartered Accountant shall be
enclosed.
- i) Bank details:
Bank name :
Branch :
Account No :
IFSC :
MICR :

Note: The Tenderer shall enclose documentary proofs for the above without fail.

ANNEXURE - V**ANNUAL TURNOVER CERTIFICATE**

The annual turnover of M/s. for the last three financial years is given below and certified that the statement is true and correct.

Sl. No.	Years	Turnover in Lakhs (Rs.)
1.	2017 – 2018	
2.	2018 – 2019	
3.	2019 – 2020	
	Total Turnover	
	Average Annual Turnover	

Signature of Tenderer with Seal

Signature of the Auditor /
Chartered Accountant
(Name in Capital with
Registration Number)

Date:

Seal:

ANNEXURE - VII

DECLARATION

I / We having the registered office at hereby declare that the Firm / Company or its Partners / Shareholders have not been blacklisted by Central / any State Government and its Public Sector Undertakings / Corporations.

**Signature of the Tenderer
with Seal**

ANNEXURE - VIII

DECLARATION

I/We having the registered office at..... declare that I/we have carefully read and accept all the terms and conditions of Tender floated by the Tamil Nadu Textbook and Educational Services Corporation, Chennai vide Tender Ref. No.10445/PUR-II/2021 for the purchase of 16.08 **lakh** boxes of Wooden Colour Pencils (Bi-colour) strictly conforming to the specifications as given in the Tender Document and I / we shall abide by all the conditions set forth therein. I/we also undertake to take back the rejected defective and the test-failed **Wooden Colour Pencil (Bi-Colour)** at our risk & cost and replace the same within the stipulated time as per instructions of Tamil Nadu Textbook and Educational Services Corporation, Chennai.

**Signature of the Tenderer
with Seal**

ANNEXURE -IX

SELF CERTIFICATION ON SAMPLE SUBMISSION

Certified that **sample** boxes of **Wooden Colour Pencil (Bi-Colour)** as per Clause 4.17.1. submitted with the tender documents **2022 – 2023** conforms to the technical specifications prescribed in **Annexure I, II (a)& (b) and III.**

.
.

**Signature of the Tenderer
with Seal**

ANNEXURE - X

DECLARATION

I / We _____ offer to supply a total quantity of Boxes of **Wooden Colour Pencil (Bi-Colour)** and deliver to the designated locations in Tamil Nadu within a period of 60 days which is inclusive of Pre Dispatch Inspection and clearance and replacement of rejected quantity during pre inspection, pre and post sample testing.

I am aware that as per Tender conditions, the minimum production capacity should be 5,000 Boxes of **Wooden Colour Pencil (Bi-Colour)** per day.

**Signature of the Tenderer
with Seal**

ANNEXURE - XI

CERTIFICATE

I/we having office at declare that the tender forms downloaded from the website www.tenders.tn.gov.in / www.textbookcorp.tn.gov.in have not been tampered with / modified in any manner. In case, if the same is found to be tampered with or modified, the Tender Document submitted by me/us shall be summarily rejected.

**Signature of the Tenderer
with Seal**

ANNEXURE – XII

FORMAT FOR AVAILABILITY OF CASH CREDIT FACILITIES -

Nationalised / Scheduled Bank Certificate

This is to certify that M/s. _____ (Name and address of the Tenderer) is a reputed company with a good financial standing.

If the contract for “the supply and delivery of **Wooden Colour Pencil (Bi-Colour)** to the School Children studying in Government & Aided schools in Tamil Nadu for the year 2022 – 2023”, is awarded to the above firm, we shall be able to provide overdraft/credit facilities to the extent of Rs. _____/- to meet their working capital requirements for executing the above contract.

Signature:

Name of Authorised signatory

Designation with seal

Address of the Bank

ANNEXURE – XIII**10. BANK GUARANTEE FOR SECURITY DEPOSIT**

To: _____ *[name of Employer]*
 _____ *[address of Employer]*

WHEREAS _____ *[name and address of Successful Tenderer]* (hereinafter called "the Successful Tenderer") has undertaken, in pursuance of Tender No. _____ dated _____ to execute _____ *[name of Contract and brief description of Works]* (hereinafter called "the Contract");

AND WHEREAS it has been stipulated by you in the said Contract that the Successful Tenderer shall furnish you with a Bank Guarantee by a recognized bank for the sum specified therein as security for compliance with his obligations in accordance with the Contract;

AND WHEREAS we have agreed to give the Successful Tenderer such a Bank Guarantee;

NOW THEREFORE we hereby affirm that we are the Guarantor and responsible to you, on behalf of the Successful Tenderer, up to a total of _____ *[amount of guarantee]*¹ _____ *[in words]*, such sum being payable in the types and proportions of currencies in which the Contract Price is payable, and we undertake to pay you, upon your first written demand and without cavil or argument, any sum or sums within the limits of _____ *[amount of guarantee]*¹ as aforesaid without your needing to prove or to show grounds or reasons for your demand for the sum specified therein.

We hereby waive the necessity of your demanding the said debt from the Successful Tenderer before presenting us with the demand.

We further agree that no change or addition to or other modification of the terms of the Contract or of the Works to be performed there under or of any of the Contract documents which may be made between you and the Successful Tenderer shall in any way release us from any liability under this guarantee, and we hereby waive notice of any such change, addition or modification.

This guarantee shall be valid until 24 Calendar months from the date of issue of Bank Guarantee.

Signature and seal of the guarantor _____

Name of Bank _____

Address _____

Date _____

¹ An amount shall be inserted by the Guarantor, representing the percentage of the Contract Price specified in the Contract including additional security for unbalanced Bids, if any and denominated in Indian Rupees.

ANNEXURE - XIV**11. AGREEMENT FORM**

(To be filled by the tenderer in a non-judicial stamp paper of value not less than Rs.100/-)

THIS AGREEMENT made the ____ day of -----, 2021 between **TAMILNADU TEXTBOOK AND EDUCATIONAL SERVICES CORPORATION, E.V.K SAMPATH MAALIGAI, NO.68, COLLEGE ROAD, CHENNAI** represented by the Member Secretary (Purchaser) of one part **and** _____
 _____ (Name and Address of Supplier) represented by _____ (Supplier) of the other part:

WHEREAS the **Purchaser** is desirous that certain Goods and ancillary services should be provided by the Supplier, viz., _____ **Tamilnadu Textbook and Educational Services Corporation** has accepted the bid of the Supplier for the supply of those goods and services for a total consideration of _____ (Rupees _____) (The Contract price including GST).

NOW THIS AGREEMENT WITNESSETH AS FOLLOWS:

1. In this Agreement words and expressions shall have the same meanings as are respectively assigned to them in the Conditions of Contract referred to.
2. The following documents shall be deemed to form and be read and construed as part of this Agreement, viz.:
 - (a) Letter of tenderer and Price Schedule submitted by the Supplier;
 - (b) Price schedule and Negotiated letter submitted by the bidder;
 - (c) Supply and Delivery of **(Wooden Colour Pencil (Bi-Colour))** as per Tender Document;
 - (b) Schedule of Requirements;
 - (c) Technical Specifications;
 - (d) General Conditions of Contract;
 - (e) Conditions of Contract; and
 - (f) Letter of Acceptance

(g) Purchase Order

(h) Agreement

(i) All Addendum issued and replies to queries and any other clarifications issued by the TNTB&ESC as forming part of the contract.

3. In consideration of the payments to be made by the **Purchaser** to the Supplier as hereinafter mentioned, the Supplier hereby covenants with the **Purchaser** to provide the Goods and Services and to remedy defects therein in conformity in all respects with the provisions of the Contract.
4. The **Purchaser** hereby agrees to pay the Supplier in consideration of the provision of the Goods and Services and the remedying of defects therein, the Contract Price or such other sum as may become payable under the provisions of the Contract at the times and in the manner prescribed by the Contract.
5. **BRIEF PARTICULARS OF THE GOODS AND SERVICES WHICH SHALL BE SUPPLIED / PROVIDED BY THE SUPPLIER ARE:**

Name of the material	Quantity allotted	Accepted Rate (Rs.)	Total Value Rs.
Total			

6. For all purposes, the instructions issued under general as well as conditions of contract specified in the terms and condition of the tender document will be binding in the Agreement signed by the contractor.
7. The supplier should supply the above material strictly as per the Terms and Conditions and technical specifications (as per Annexure) stipulated in the Tender document within Sixty days (60) from the date of issue of Purchase Order.
8. The Corporation reserves the right to withhold the GST amount charged by the supplier in the Tax invoices submitted to the Corporation in the event of

failure to pay the GST amount to the Government or / and in the event of such amount paid by the supplier as GST are not reflected in the returns against, the Corporation's name mandated under the law.

9. The Corporation shall recover any dues from the Successful Tenderer if found to be recoverable on a later date in any audit even after settlement of the Bill.The Successful Tenderer shall be liable to pay such dues to the Corporation.

10. Address of the local office and the details of the responsible person in the local office are furnished below (applicable for the successful Tenderer from outside the State of Tamil Nadu).

IN WITNESS whereof the parties hereto have caused this Agreement to be executed in accordance with their respective laws the day and year first above written.

(Signature of the Purchaser
with Name and Address)

(Signature of the supplier
with Name and Address)

Address with office seal in the presence of Witnesses :

1).....

1).....

2).....

2).....

PART - B**12. PRICE BID
(TO BE FURNISHED IN PART - B COVER)****SCHEDULE OF RATES - BOX CONTAINING 6 PIECES OF WOODEN
COLOUR PENCIL (BI-COLOUR) AS PER SPECIFICATIONS INCLUDING
DELIVERY COST TO THE DESIGNATED LOCATIONS**

SI.No	Details	Rate per box of Wooden Colour Pencil (Bi-Colour)	
		Amount (Rs. in Figures)	Amount (Rs. in Words)
1.	Basic Cost		
2.	GST		
3.	Others, if any (to be specified)		
	TOTAL COST		

**Signature of the Tenderer
with Seal**